

POWER DESIGN

DC5V_IN

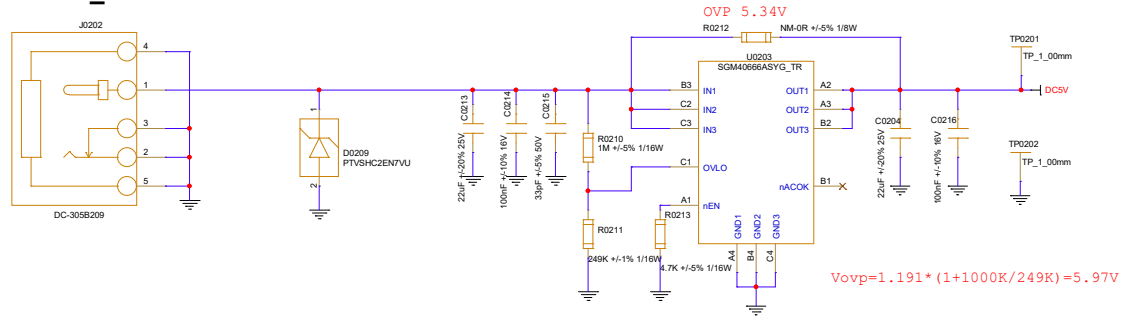

PWR consumption Test

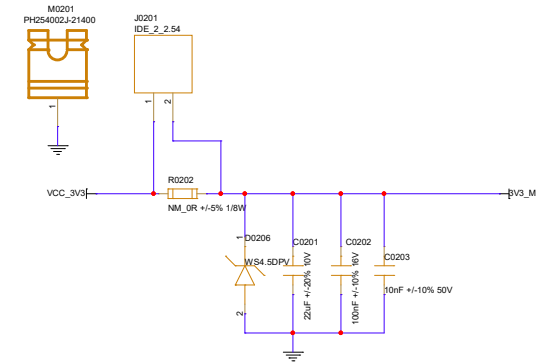

USB_5V_IN

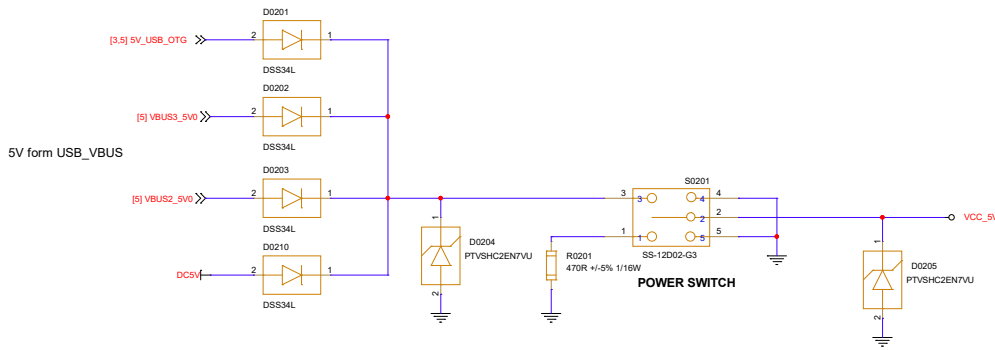

POWER_LED

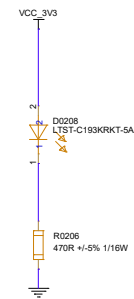

DCDC:3V3

$$V_{OUT} = 0.6 * (1 + R1/R2) = 3.35V, R1=110K, R2=24K$$

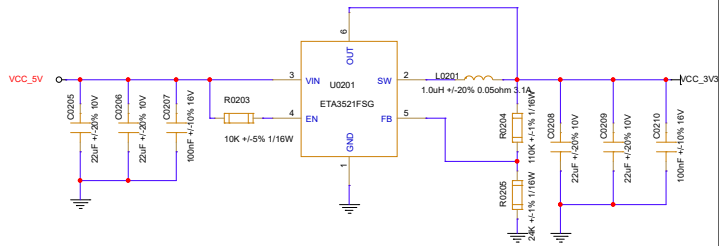

LDO:1V8

$$V_{OUT} = 0.8 * (1 + R1/R2) = 1.82V, R1=25.5K, R2=20K$$

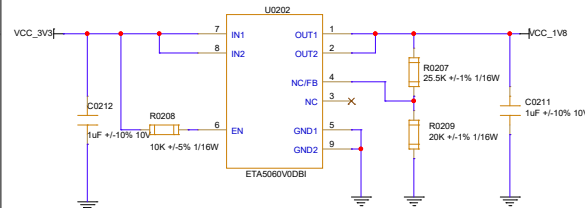

LABE

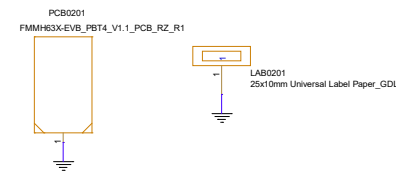

SCREW HOLE

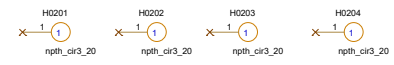

M2_KeyE CONNECTER



UART2,3&SWD

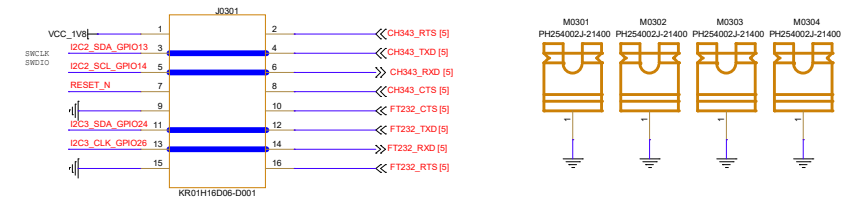

UART0&SPI&GPIO

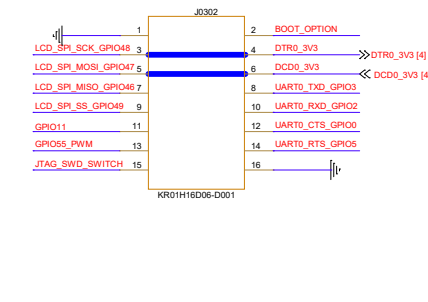

GPIO&BOOT

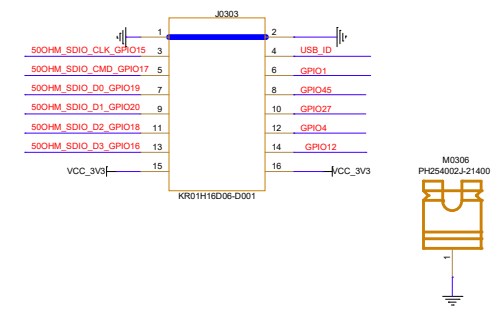

BOOT_OPTION	BOOT
1	Flash (default)
0	ISP

BUTTON

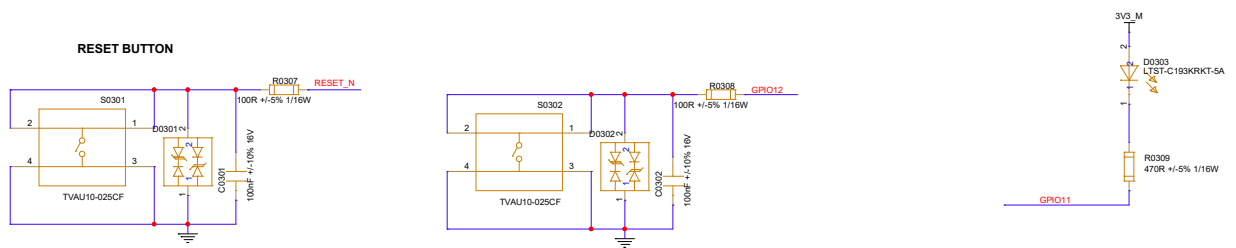

Voltage-Level Translator

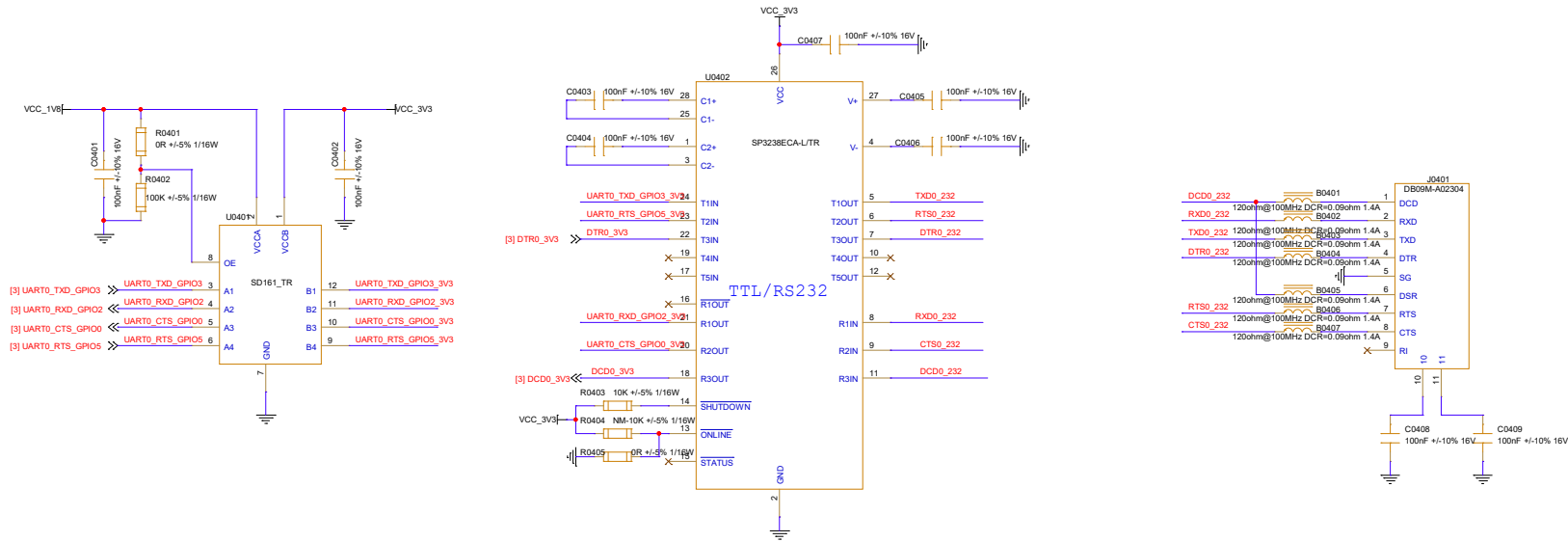

AT_UART

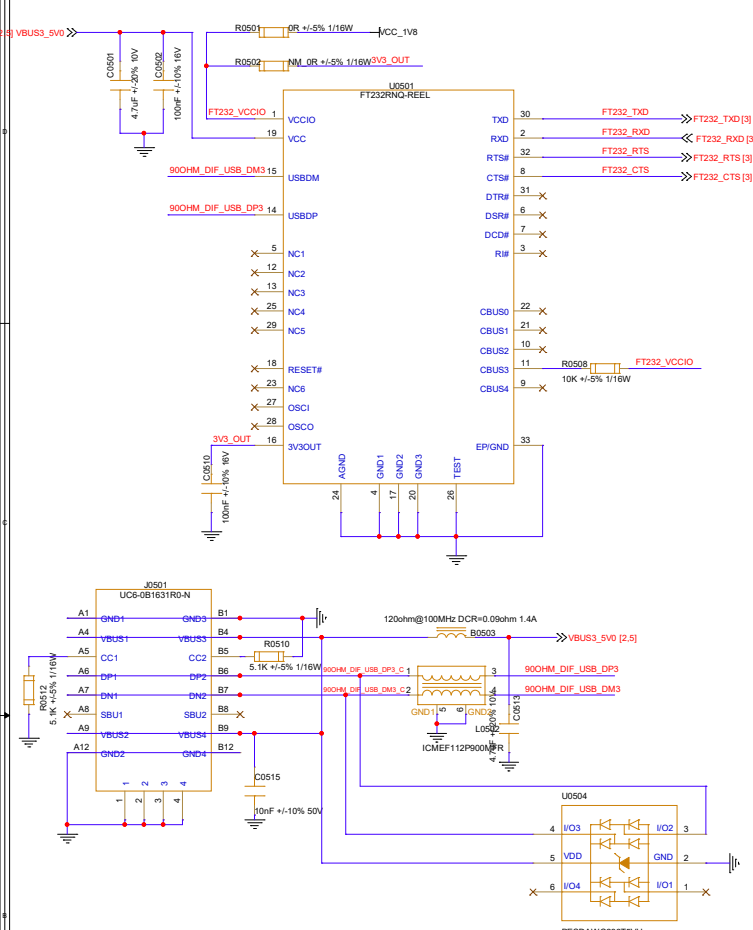

DEBUG_UART

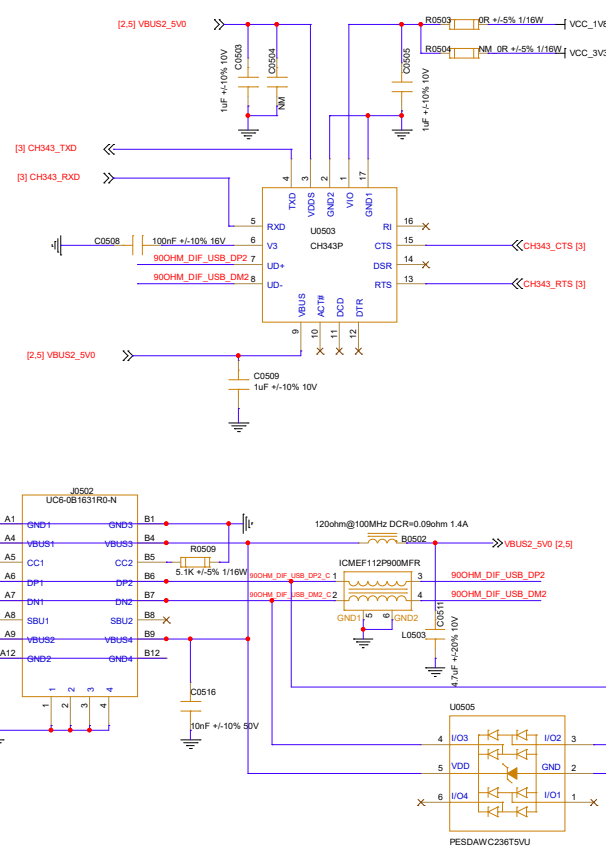

USB_PORT

USB ID is a processor Analog Sense Input
 Host --> ID = GND
 Device --> ID = Floating

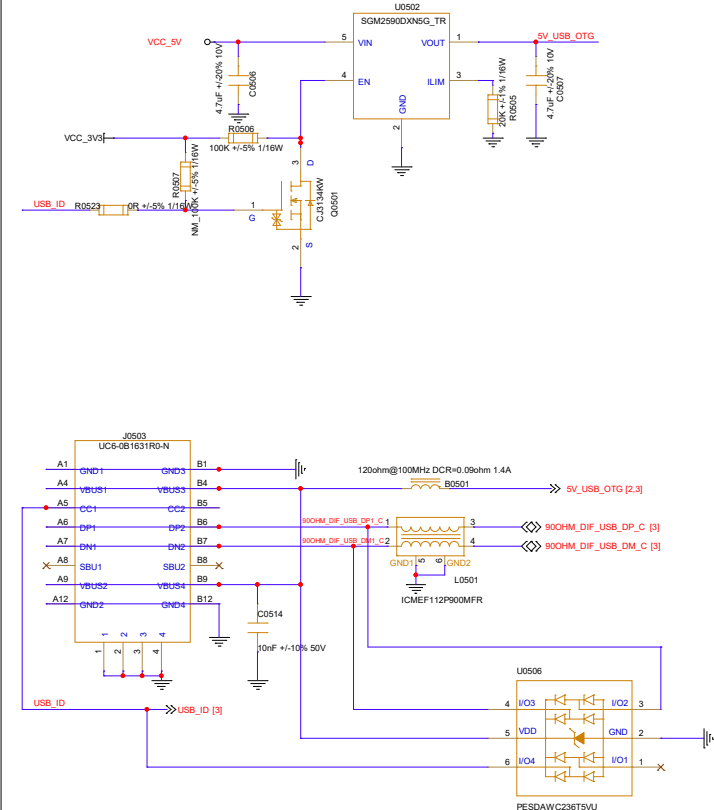

JTAG

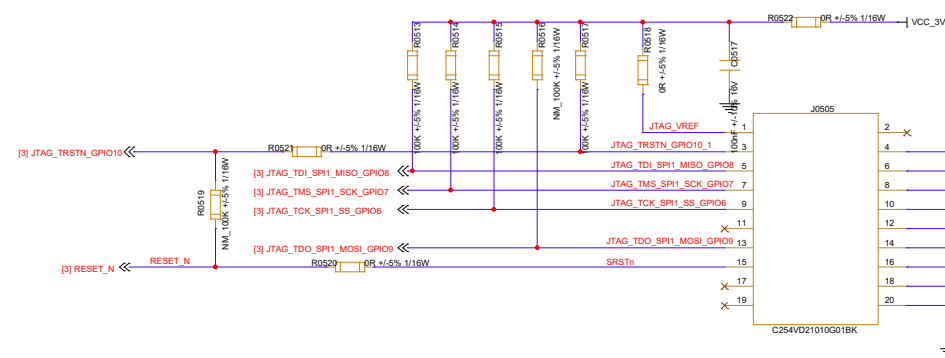

Ethernet

